

Frese MODULA Compact

Complete solutions for balancing and temperature control

Application

Frese MODULA Compact is a versatile valve system that combines the Frese range of pressure independent control valves with isolation, flushing, draining and measurement components within a prefabricated, tested and ready to install terminal connection assembly.

The patented design has an integrated metering station for accurate flow verification.

Frese MODULA Compact integrates Frese OPTIMA Compact (Pressure Independent Control Valve - PICV)

With isolation valves and P/T plugs.



Benefits

Design

- Minimized design time and risks due to complete solution
- Guaranteed performance of the complete system
- Compact design for limited space availability
- Fitted with OPTIMA Compact PICV
- Integrated Metering Station
- Compact design for installations with limited space

Simplified installation

- Minimized installation and commissioning costs
- Allows easy flushing and coil isolation
- Easy lagging with spindle extensions
- Can be mounted directly to a terminal unit

Operation

- High comfort with minimized operation and maintenance costs

For further information on the OPTIMA Compact PICV, please refer to the relevant technotes

Features

- Integrated metering station for accurate flow verification. Available Kv-values: 0.3 - 0.9 - 2.8 - 8.0
- Available in DN15 and DN20
- Patented Frese OPTIMA Compact PICV technology
- Compact 40mm supply/return centres on DN15 and 50mm supply/return centres on DN20
- Integrated union joints for easy valve alignment
- T-handle isolation-valves for flow, return and bypass.
- Spindle extensions available

Frese MODULA Compact Complete solutions for balancing and temperature control

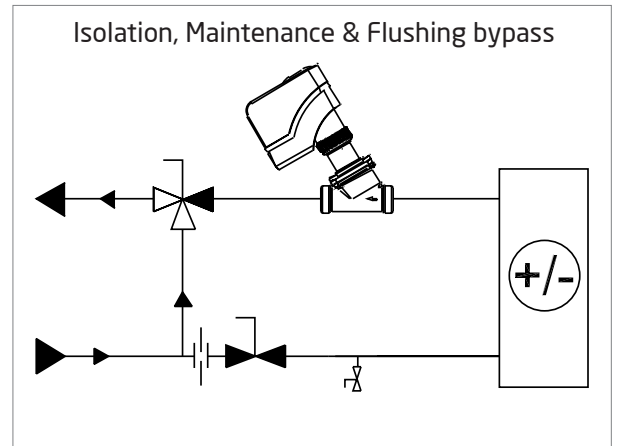
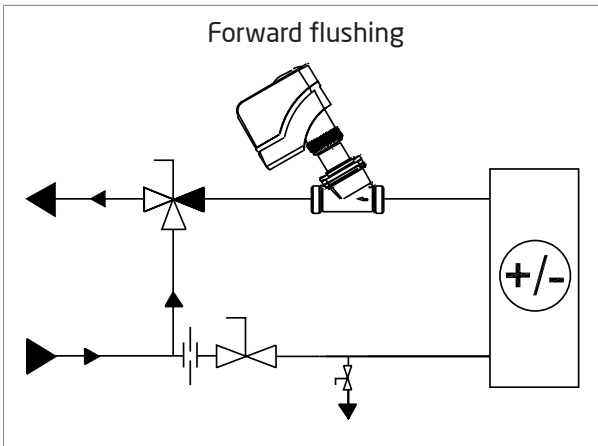
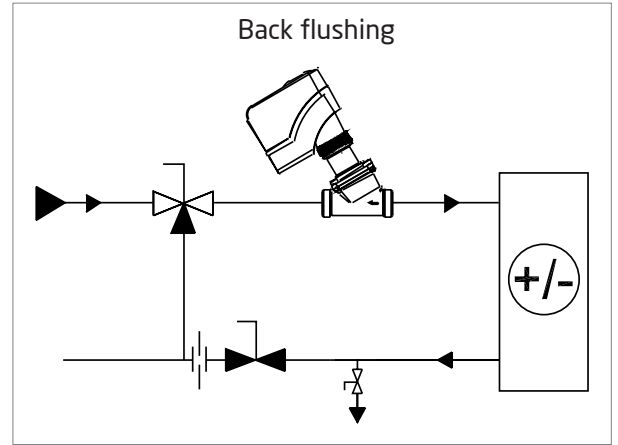
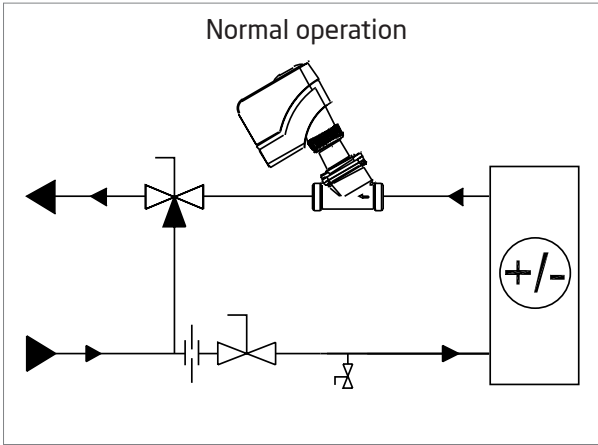

Flow graphs for Metering station

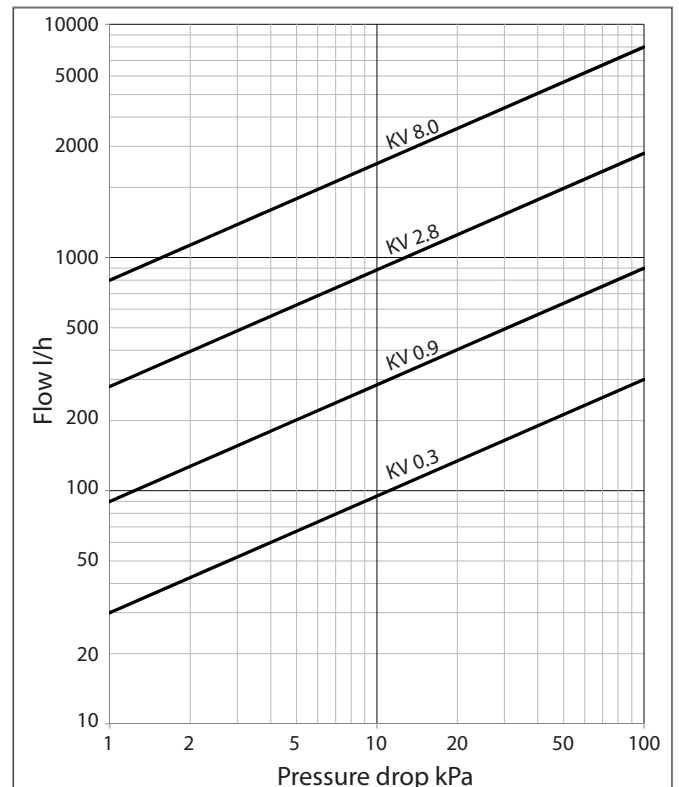
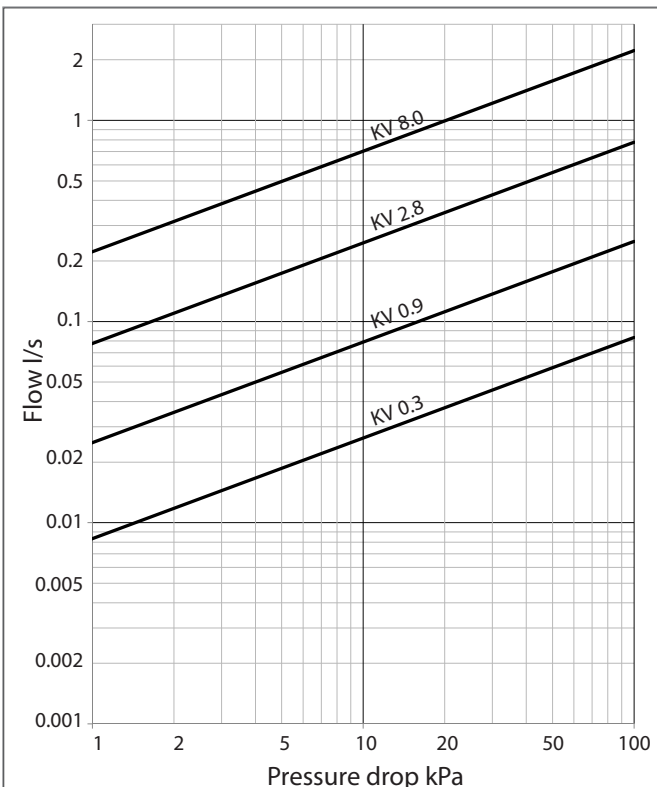

Frese MODULA Compact Complete solutions for balancing and temperature control

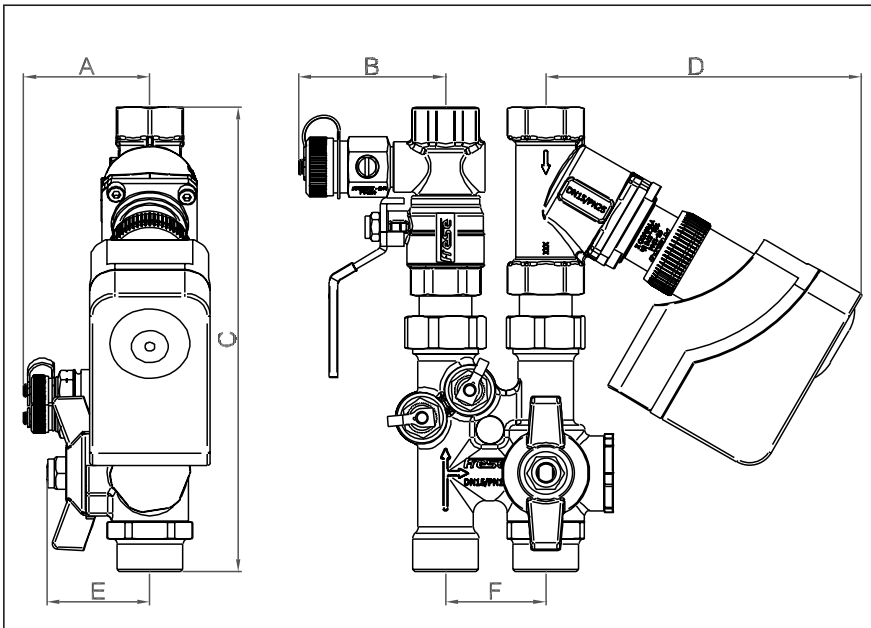

MODULA Compact

	DN15	DN20	
A	50	50	
B	59	59	
C	186	206	
D	126	126	
E	41/88		Std./Ext Handle
F	40	50	

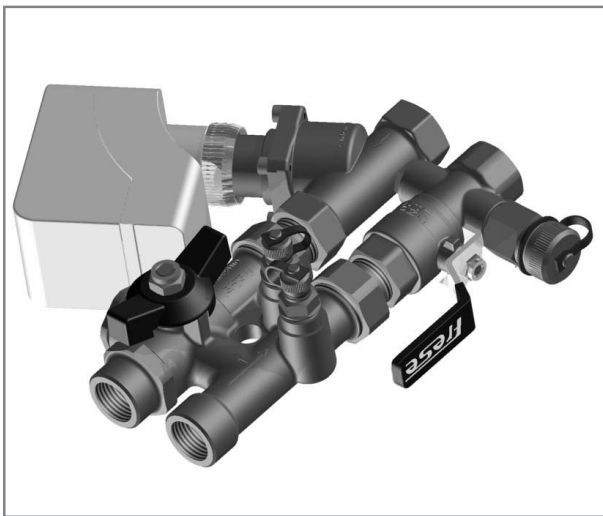

Right hand version

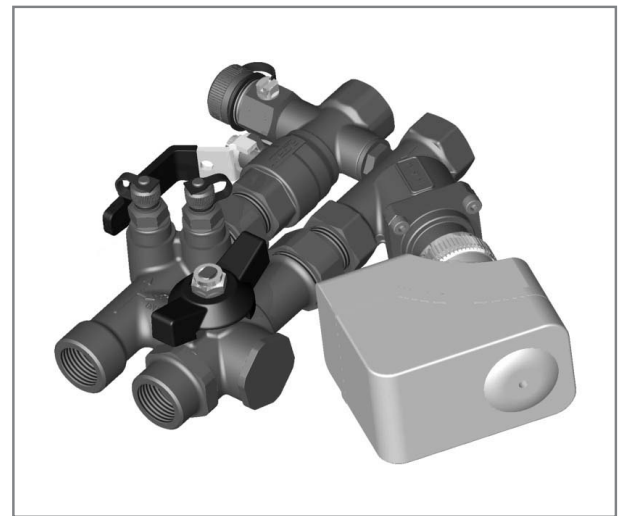

Left hand version

Frese A/S assumes no responsibility for errors, if any, in catalogues, brochures, and other printed matter. Frese A/S reserves the right to modify its products without prior notice, including already ordered products, if this does not alter existing specifications. All registered trademarks in this material are the property of Frese A/S. All rights reserved.

Frese A/S
Sorøvej 8
DK- 4200 Slagelse
Tel: +45 58 56 00 00
Fax: +45 58 56 00 91
info@frese.dk